

# ICP PNEUMATIC

## Pneumatic Tire Lift Trucks Diesel/LPG

<b>CMP50</b>	11,000 lbs 5000 kg
<b>CMP60</b>	13,500 lbs 6000 kg
<b>CMP70</b>	15,500 lbs 7000 kg
<b>CMP75S</b>	16,500 lbs 7500 kg

# CMP50/60 70/75S

**M** Series



**CLARK**<sup>®</sup>  
BUILT TO LAST.<sup>®</sup>

w w w . c l a r k m h c . c o m

For corresponding data see Specification Chart.

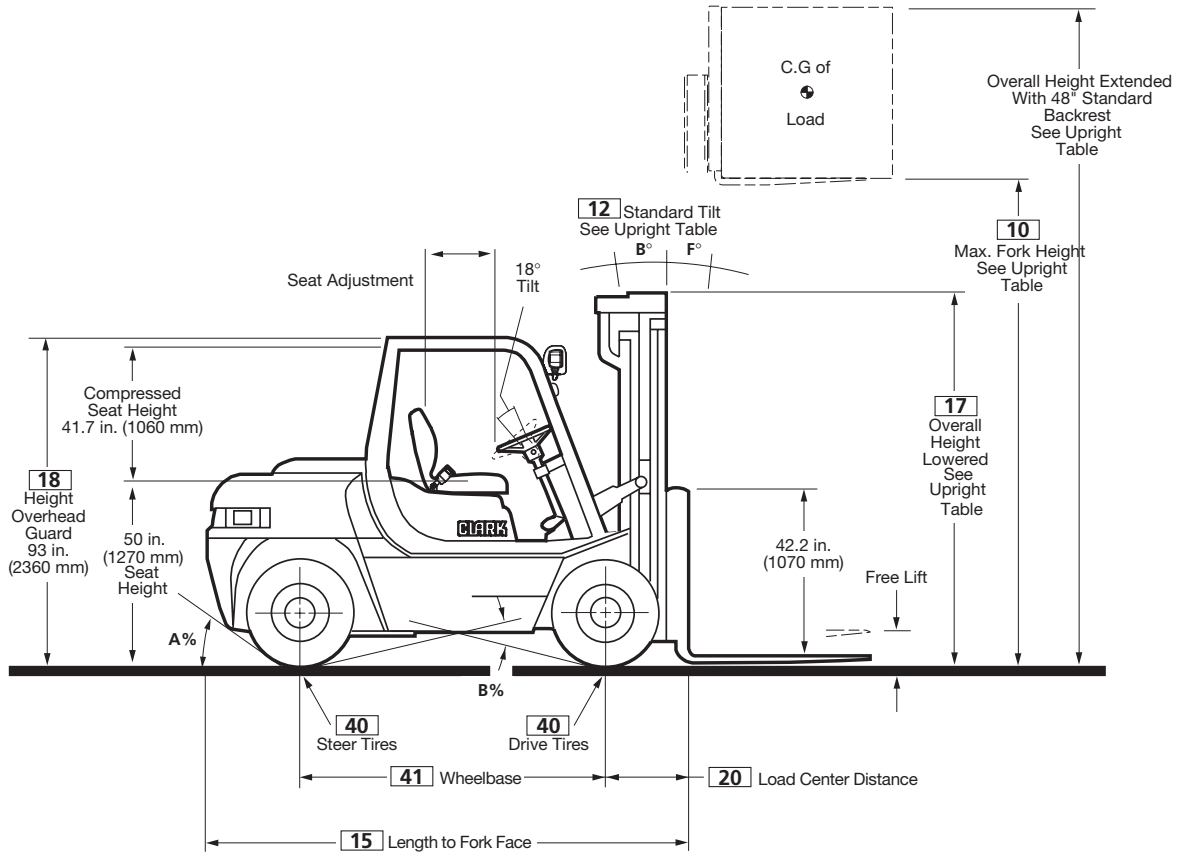

# CMP50/60/70/75S

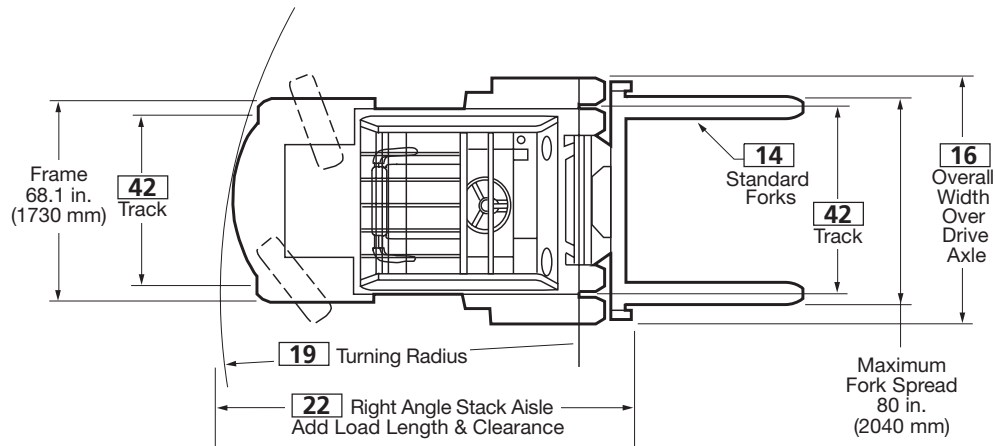

Notes: **1** Weights and performance information are given for the truck equipped with the 137 in. (3500 mm) standard upright.  
**2** Add 0.75 in. (19mm) for triple stage upright.  
**3** Limited only by grade clearance angle.

General Information				Clark	Clark
1	Manufacturer			Clark	Clark
2	Model	Manufacturer's Designation		CMP50	CMP60
3	Load Capacity		lbs(kg)	11,000 (5000)	13,500 (6000)
4	Load Center	Fork Face Load CG	in(mm)	24 (600)	24 (600)
5	Drive Unit	Type		Diesel	Diesel
6	Operator Type			Rider Counterbalanced	Rider Counterbalanced
7	Tire Type			Pneumatic	Pneumatic
8	Wheels (x=driven)	Front/Rear		4x / 2	4x / 2
Basic Dimensions					
9	Upright <sup>1,2</sup>	Maximum Fork Height, Full Capacity	in(mm)	157 (4000)	157 (4000)
10		Lift Height (preferred standard upright)	in(mm)	137 (3500)	137 (3500)
11		Free Lift	in(mm)	4.3 (110)	4.3 (110)
12	Upright Tilt	Back/Forward (See Upright Table)	degrees	10 / 15	10 / 15
14	Fork	Std. Fork Size (T x W x L)-Pin Mount	in(mm)	2.4 x 6 x 48 (60 x 150 x 1220)	2.4 x 6 x 48 (60 x 150 x 1220)
15	Overall Dimensions	Length to Fork Face	in(mm)	137 (3470)	139 (3530)
16		Width over drive axle	in(mm)	83 (2115)	83 (2115)
		Height, Upright Lowered	in(mm)	108 (2750)	108 (2750)
		Height, Upright Extended	in(mm)	186 (4720)	186 (4720)
18		Height, overhead guard	in(mm)	93 (2360)	93 (2360)
19	Turning Radius		in(mm)	132.3 (3360)	134.3 (3410)
20	Load Center Distance	Center of Drive Axle to Fork Face	in(mm)	24.8 (630)	24.8 (630)
22	Right Angle Stack Aisle	Add Load Length and Clearance	in(mm)	157.1 (3990)	159.1 (4040)
Performance <sup>1,3</sup>					
23	Stability	According to ANSI/DIN		Yes	Yes
24	Speeds	Travel Speed, Max w/ Load	mph(kph)	16.6 (26.7)	16.3 (26.2)
25		Travel Speed, Max w/o Load	mph(kph)	17.8 (28.6)	17.7 (28.4)
		Speed on Grade	mph(kph)		
		5%, Loaded	mph(kph)	(3rd Gear) 9.6 (15.5)	(3rd Gear) 8.3 (13.3)
		10%, Loaded	mph(kph)	(2nd Gear) 5.5 (8.9)	(2nd Gear) 5.3 (8.5)
		15%, Loaded	mph(kph)	(2nd Gear) 3.9 (6.2)	(2nd Gear) 3.3 (5.3)
26	Lift Speeds, Loaded/Empty	Standard	fpm(ms)	83/83 (.42/.42)	83/83 (.42/.42)
28					
29	Lower Speeds, Loaded/Empty	Standard	fpm(ms)	85/85 (.43/.43)	85/85 (.43/.43)
30	Drawbar Pull, Maximum	With Load	lbs(n)	17,289 (76900)	17,875 (79500)
31		Without Load	lbs(n)	4,880 (24781)	4,900 (21770)
32	Gradeability <sup>3</sup>	At 1 mph (1.6 kph) with load (low range)/No Load %		50.2 / 23.0	45.8 / 21.5
Weights <sup>1</sup>					
34	Service weight		lbs(kg)	18,867 (8558)	20,101 (9118)
35	Axle loading	With Load, Front	lbs(kg)	26,473 (12008)	29,962 (13591)
36		With Load, Rear	lbs(kg)	3,417 (1550)	3,366 (1527)
37		W/O Load, Front	lbs(kg)	9,285 (4212)	9,338 (4236)
38		W/O Load, Rear	lbs(kg)	9,581 (4346)	10,762 (4882)
Chassis					
39	Tires	Number, Front/Rear		4 / 2	4 / 2
40		Size, Front	in	8.25 x 15 - 14 ply rating	8.25 x 15 - 14 ply rating
			in		
41	Wheelbase		in(mm)	86.6 / 2200	86.6 / 2200
42	Track	Front/Rear	in(mm)	62.4/58.9 (1584/1495)	62.4/58.9 (1584/1495)
44	Ground Clearance	Minimum at Center of Wheelbase	in(mm)	8.1/10.0 / 205/254	8.1/10.0 / 205/254
46	Service Brake	Type		Power Assist Drum & Shoe	Power Assist Drum & Shoe
47	Parking Brake	Actuation		Lever	Lever
	Steering	Type		Hydrostatic	Hydrostatic
Drive Line					
49	Engine	Manufacturer/Model		Perkins / 1104C-44	Perkins / 1104C-44
51		Rated Output <sup>2</sup>	HP/kW @ rpm	82.8/61.5 @ 2200	82.8/61.5 @ 2200
		Torque	lb-ft/Nm @ rpm	223/303 @ 1400	223/303 @ 1400
52		Speed, max Governed	rpm	2400	2400
53		Cylinders/Displacement	cu. in.-Liters	4 / 268 / 4.4	4 / 268 / 4.4
54	Transmission	Manufacturer/Type, Speeds F/R		Clark/T12000 Series, 3/3	Clark/T12000 Series, 3/3
57	Hydraulic Pressure	For Attachments		2030 / 140	2030 / 140
58	Sound Level	Avg. at Operator's Ear per ASME B56.11.5	dB(A)	83	83

# S P E C I F I C A T I O N S

General Information	1	Manufacturer		Clark	Clark	
	2	Model	Manufacturer's Designation	CMP70	CMP75S	
	3	Load Capacity	lbs(kg)	15,500 (7000)	16,500 (7500)	
	4	Load Center	Fork Face Load CG	in(mm)	24 (600)	24 (600)
	5	Drive Unit	Type	Diesel	Diesel	
	6	Operator Type		Rider Counterbalanced	Rider Counterbalanced	
	7	Tire Type		Pneumatic	Pneumatic	
	8	Wheels (x=driven)	Front/Rear	4x / 2	4x / 2	
Basic Dimensions	9	Upright <sup>1,2</sup>	Maximum Fork Height, Full Capacity	in(mm)	157 (4000)	137 (3500)
	10		Lift Height (preferred standard upright)	in(mm)	137 (3500)	137(3500)
	11		Free Lift	in(mm)	4.3 (110)	4.3 (110)
	12	Upright Tilt	Back/Forward (See Upright Table)	degrees	10 / 15	10 / 15
	14	Fork	Std. Fork Size (T x W x L)-Pin Mount	in(mm)	2.4 x 6 x 48 (60 x 150 x 1220)	2.4 x 7 x 48 (60 x 180 x 1220)
	15	Overall Dimensions	Length to Fork Face	in(mm)	141 (3590)	141 (3590)
	16		Width over drive axle	in(mm)	83 (2115)	83 (2115)
			Height, Upright Lowered	in(mm)	108 (2750)	108 (2750)
			Height, Upright Extended	in(mm)	186 (4720)	186 (4720)
	18		Height, overhead guard	in(mm)	93 (2360)	93 (2360)
	19	Turning Radius		in(mm)	136.6 (3470)	136.6 (3470)
	20	Load Center Distance	Center of Drive Axle to Fork Face	in(mm)	24.8 (630)	24.8 (630)
22	Right Angle Stack Aisle	Add Load Length and Clearance	in(mm)	161.4 (4100)	161.4 (4100)	
Performance <sup>1,3</sup>	23	Stability	According to ANSI/DIN		Yes	Yes
	24	Speeds	Travel Speed, Max w/ Load	mph(kph)	16.0 (25.7)	15.8 (25.4)
	25		Travel Speed, Max w/o Load	mph(kph)	17.7 (28.4)	17.6 (28.3)
		Speed on Grade	5%, Loaded	mph(kph)	(2nd Gear) 6.2 (9.9)	(2nd Gear) 5.7 (9.2)
			10%, Loaded	mph(kph)	(2nd Gear) 3.9 (6.3)	(2nd Gear) 3.7 (6.0)
			15%, Loaded	mph(kph)	(3rd Gear) 3.0 (4.8)	(2nd Gear) 2.7 (4.4)
	26	Lift Speeds, Loaded/Empty	Standard	fpm(ms)	73/83 (.37/.42)	73/83 (.37/.42)
	28					
	29	Lower Speeds, Loaded/Empty	Standard	fpm(ms)	85/85 (.43/.43)	85/85 (.43/.43)
30	Drawbar Pull, Maximum	With Load	lbs(n)	16,190 (72025)	18,100 (80500)	
31		Without Load	lbs(n)	4,800 (21375)	4,870 (21600)	
32	Gradeability <sup>3</sup>	At 1 mph (1.6 kph) with load (low range)/No Load	%	33.0 / 19.4	33.4 / 19.4	
Weights <sup>1</sup>	34	Service weight	lbs(kg)	21,490 (9748)	22,0152 (9986)	
	35	Axle loading	With Load, Front	lbs(kg)	33,274 (15093)	35,124 (15932)
	36		With Load, Rear	lbs(kg)	3,648 (1655)	8,774 (1554)
	37		W/O Load, Front	lbs(kg)	9,213 (4179)	9,345 (4239)
	38		W/O Load, Rear	lbs(kg)	12,277 (5569)	12,669 (5747)
Chassis	39	Tires	Number, Front/Rear		4 / 2	4 / 2
	40		Size, Front	in	8.25 x 15 - 14 ply rating	8.25 x 15 - 14 ply rating
				in		
	41	Wheelbase		in(mm)	86.6 (2200)	86.6 (2200)
	42	Track	Front/Rear	in(mm)	62.4/58.9 (1584/1495)	62.4/58.9 (1584/1495)
	44	Ground Clearance	Minimum at Center of Wheelbase	in(mm)	8.1/10.0 (205/254)	8.1/10.0 (205/254)
	46	Service Brake	Type		Power Assist Drum & Shoe	Power Assist Drum & Shoe
	47	Parking Brake	Actuation		Lever	Lever
	Steering	Type		Hydrostatic	Hydrostatic	
Drive Line	49	Engine	Manufacturer/Model		Perkins / 1104C-44	Perkins / 1104C-44
	51		Rated Output <sup>2</sup>	HP/kW @ rpm	82.8/61.5 @ 2200	82.8/61.5 @ 2200
			Torque	lb-ft/Nm @ rpm	223/303 @ 1400	223/303 @ 1400
	52		Speed, max Governed	rpm	2400	2400
	53		Cylinders/Displacement	cu. in.-Liters	4 / 268 / 4.4	4 / 268 / 4.4
	54	Transmission	Manufacturer/Type, Speeds F/R		Clark/T12000 Series, 3/3	Clark/T12000 Series, 3/3
57	Hydraulic Pressure	For Attachments		2030 / 140	2030 / 140	
58	Sound Level	Avg. at Operator's Ear per ASME B56.11.5	dB(A)	83	83	

<sup>2</sup> Add 0.75 in. (19mm) for triple stage upright.  
<sup>3</sup> Limited only by grade clearance angle.

**Notes:**  
<sup>1</sup> Weights and performance information are given for the truck equipped with the 137 in. (3500 mm) standard upright.

<b>General Information</b>	1	Manufacturer		Clark	Clark	
	2	Model	Manufacturer's Designation	CMP50	CMP60	
	3	Load Capacity	lbs(kg)	11,000 (5000)	13,500 (6000)	
	4	Load Center	Fork Face Load CG	in(mm)	24 (600)	24 (600)
	5	Drive Unit	Type	LPG	LPG	
	6	Operator Type		Rider Counterbalanced	Rider Counterbalanced	
	7	Tire Type		Pneumatic	Pneumatic	
	8	Wheels (x=driven)	Front/Rear	4x / 2	4x / 2	
<b>Basic Dimensions</b>	9	Upright <sup>1,2</sup>	Maximum Fork Height, Full Capacity	in(mm)	157 (4000)	157 (4000)
	10		Lift Height (preferred standard upright)	in(mm)	137 (3500)	137 (3500)
	11		Free Lift	in(mm)	4.3 (110)	4.3 (110)
	12	Upright Tilt	Back/Forward (See Upright Table)	degrees	10 / 15	10 / 15
	14	Fork	Std. Fork Size (T x W x L)-Pin Mount	in(mm)	2.4 x 6 x 48 (60 x 150 x 1220)	2.4 x 6 x 48 (60 x 150 x 1220)
	15	Overall Dimensions	Length to Fork Face	in(mm)	137 (3470)	139 (3530)
	16		Width over drive axle	in(mm)	83 (2115)	83 (2115)
			Height, Upright Lowered	in(mm)	108 (2750)	108 (2750)
			Height, Upright Extended	in(mm)	186 (4720)	186 (4720)
	18		Height, overhead guard	in(mm)	93 (2360)	93 (2360)
	19	Turning Radius		in(mm)	132.3 (3360)	134.3 (3410)
	20	Load Center Distance	Center of Drive Axle to Fork Face	in(mm)	24.8 (630)	24.8 (630)
22	Right Angle Stack Aisle	Add Load Length and Clearance	in(mm)	157.1 (3990)	159.1 (4040)	
<b>Performance<sup>1,3</sup></b>	23	Stability	According to ANSI/DIN	Yes	Yes	
	24	Speeds	Travel Speed, Max w/ Load	mph(kph)	16.5 (26.5)	16.2 (26.1)
	25		Travel Speed, Max w/o Load	mph(kph)	17.2 (27.7)	17.1 (27.6)
		Speed on Grade	5%, Loaded	mph(kph)	7.8 (12.6)	6.4 (10.4)
			10%, Loaded	mph(kph)	3.2 (5.2)	4.6 (7.4)
			15%, Loaded	mph(kph)	3.2 (5.2)	3.1 (5.2)
	26	Lift Speeds, Loaded/Empty	Standard	fpm(ms)	83/83 (.42/.42)	83/83 (.42/.42)
	28					
	29	Lower Speeds, Loaded/Empty	Standard	fpm(ms)	85/85 (.43/.43)	85/85 (.43/.43)
30	Drawbar Pull, Maximum	With Load	lbs(n)	15,900 (70,770)	16,050 (71400)	
31		Without Load	lbs(n)	4,882 (21,717)	4,900 (21775)	
32	Gradeability <sup>3</sup>	At 1 mph (1.6 kph) loaded (low range)/No Load	%	45.3 / 22.9	40.0 / 21.5	
<b>Weights<sup>1</sup></b>	34	Service weight	lbs(kg)	18,867 (8558)	20,101 (9118)	
	35	Axle loading	With Load, Front	lbs(kg)	26,473 (12008)	29,962 (13591)
	36		With Load, Rear	lbs(kg)	3,417 (1550)	3,366 (1527)
	37		W/O Load, Front	lbs(kg)	9,285 (4212)	9,338 (4236)
	38		W/O Load, Rear	lbs(kg)	9,581 (4346)	10,762 (4882)
<b>Chassis</b>	39	Tires	Number, Front/Rear	4 / 2	4 / 2	
	40		Size, Front	in	8.25 x 15 - 14 ply rating	8.25 x 15 - 14 ply rating
				in		
	41	Wheelbase		in(mm)	86.6 / 2200	86.6 / 2200
	42	Track	Front/Rear	in(mm)	62.4/58.9 (1584/1495)	62.4/58.9 (1584/1495)
	44	Ground Clearance	Minimum at Center of Wheelbase	in(mm)	8.1/10.0 / 205/254	8.1/10.0 / 205/254
	46	Service Brake	Type		Power Assist Drum & Shoe	Power Assist Drum & Shoe
	47	Parking Brake	Actuation		Lever	Lever
	Steering	Type		Hydrostatic	Hydrostatic	
<b>Drive Line</b>	49	Engine	Manufacturer/Model		GM/Vortec 4300LT	GM/Vortec 4300LT
	51		Rated Output <sup>2</sup>	HP/kW @ rpm	93/69 @ 2400	93/69 @ 2400
			Torque	lb-ft/Nm @ rpm	235/318 @ 2000	235/318 @ 2000
	52		Speed, max Governed	rpm	2650	2650
	53		Cylinders/Displacement	cu. in.-Liters	6 / 262 / 4.3	6 / 262 / 4.3
	54	Transmission	Manufacturer/Type, Speeds F/R		Clark T12000 Series, 3/3	Clark T12000 Series, 3/3
	57	Hydraulic Pressure	For Attachments		2030 / 140	2030 / 140
58	Sound Level	Avg. at Operator's Ear per ASME B56.11.5	dB(A)	83	83	

Notes: 1 Weights and performance information are given for the truck equipped with the 137 in. (3500 mm) standard upright.

2 Add 0.75 in. (19mm) for triple stage upright.  
3 Limited only by grade clearance angle.

# SPECIFICATIONS

General Information	1	Manufacturer		Clark	Clark	
	2	Model	Manufacturer's Designation	CMP70	CMP75S	
	3	Load Capacity	lbs(kg)	15,500 (7000)	16,500 (7500)	
	4	Load Center	Fork Face Load CG	in(mm)	24 (600)	24 (600)
	5	Drive Unit	Type	LPG	LPG	
	6	Operator Type		Rider Counterbalanced	Rider Counterbalanced	
	7	Tire Type		Pneumatic	Pneumatic	
	8	Wheels (x=driven)	Front/Rear	4x / 2	4x / 2	
Basic Dimensions	9	Upright <sup>1,2</sup>	Maximum Fork Height, Full Capacity	in(mm)	157 (4000)	137 (3500)
	10		Lift Height (preferred standard upright)	in(mm)	137 (3500)	137(3500)
	11		Free Lift	in(mm)	4.3 (110)	4.3 (110)
	12	Upright Tilt	Back/Forward (See Upright Table)	degrees	10 / 15	10 / 15
	14	Fork	Std. Fork Size (T x W x L)-Pin Mount	in(mm)	2.4 x 6 x 48 (60 x 150 x 1220)	2.4 x 7 x 48 (60 x 180 x 1220)
	15	Overall Dimensions	Length to Fork Face	in(mm)	141 (3590)	141 (3590)
	16		Width over drive axle	in(mm)	83 (2115)	83 (2115)
			Height, Upright Lowered	in(mm)	108 (2750)	108 (2750)
			Height, Upright Extended	in(mm)	186 (4720)	186 (4720)
	18		Height, overhead guard	in(mm)	93 (2360)	93 (2360)
	19	Turning Radius		in(mm)	136.6 (3470)	136.6 (3470)
	20	Load Center Distance	Center of Drive Axle to Fork Face	in(mm)	24.8 (630)	24.8 (630)
22	Right Angle Stack Aisle	Add Load Length and Clearance	in(mm)	161.4 (4100)	161.4 (4100)	
Performance <sup>1,3</sup>	23	Stability	According to ANSI/DIN		Yes	Yes
	24	Speeds	Travel Speed, Max w/ Load	mph(kph)	16.0 (25.7)	13.7 (22.0)
	25		Travel Speed, Max w/o Load	mph(kph)	17.1 (27.5)	17.1 (27.5)
		Speed on Grade	5%, Loaded	mph(kph)	5.0 (8.1)	3.2 (5.1)
			10%, Loaded	mph(kph)	3.9 (6.3)	3.1 (5.0)
			15%, Loaded	mph(kph)	3.0 (4.8)	2.5 (4.0)
	26	Lift Speeds, Loaded/Empty	Standard	fpm(ms)	73/83 (.37/.42)	73/83 (.37/.42)
	28					
	29	Lower Speeds, Loaded/Empty	Standard	fpm(ms)	85/85 (.43/.43)	85/85 (.43/.43)
30	Drawbar Pull, Maximum	With Load	lbs(n)	16,190 (72025)	16,270 (72375)	
31		Without Load	lbs(n)	4,800 (21300)	4,872 (21670)	
32	Gradeability <sup>3</sup>	At 1 mph (1.6 kph) with load (low range)/No Load	%	33.0 / 19.7	27.7 / 19.4	
Weights <sup>1</sup>	34	Service weight	lbs(kg)	21,490 (9748)	22,0152 (9986)	
	35	Axle loading	With Load, Front	lbs(kg)	33,274 (15093)	35,124 (15932)
	36		With Load, Rear	lbs(kg)	3,648 (1655)	8,774 (1554)
	37		W/O Load, Front	lbs(kg)	9,213 (4179)	9,345 (4239)
	38		W/O Load, Rear	lbs(kg)	12,277 (5569)	12,669 (5747)
Chassis	39	Tires	Number, Front/Rear		4 / 2	4 / 2
	40		Size, Front	in	8.25 x 15 - 14 ply rating	8.25 x 15 - 14 ply rating
				in		
	41	Wheelbase		in(mm)	86.6 (2200)	86.6 (2200)
	42	Track	Front/Rear	in(mm)	62.4/58.9 (1584/1495)	62.4/58.9 (1584/1495)
	44	Ground Clearance	Minimum at Center of Wheelbase	in(mm)	8.1/10.0 (205/254)	8.1/10.0 (205/254)
	46	Service Brake	Type		Power Assist Drum & Shoe	Power Assist Drum & Shoe
	47	Parking Brake	Actuation		Lever	Lever
	Steering	Type		Hydrostatic	Hydrostatic	
Drive Line	49	Engine	Manufacturer/Model		GM/Vortec 4300LT	GM/Vortec 4300LT
	51		Rated Output <sup>2</sup>	HP/kW @ rpm	93/69 @ 2400	93/69 @ 2400
			Torque	lb-ft/Nm @ rpm	235/318 @ 2000	235/318 @ 2000
	52		Speed, max Governed	rpm	2650	2650
	53		Cylinders/Displacement	cu. in.-Liters	6 / 262 / 4.3	6 / 262 / 4.3
	54	Transmission	Manufacturer/Type, Speeds F/R		Clark T12000 Series, 3/3	Clark/T12000 Series, 3/3
57	Hydraulic Pressure	For Attachments		2030 / 140	2030 / 140	
58	Sound Level	Avg. at Operator's Ear per ASME B56.11.5	dB(A)	81	81	

<sup>2</sup> Add 0.75 in. (19mm) for triple stage upright.  
<sup>3</sup> Limited only by grade clearance angle.

<sup>1</sup> Weights and performance information are given for the truck equipped with the 137 in. (3500 mm) standard upright.

Notes:

**CLARK CMP50 SERIES** pneumatic tire trucks are designed to provide high levels of reliability through the use of durable components and rugged construction. Suited to demanding applications such as handling building materials, concrete products, warehousing and stevedoring operations. With diesel or LPG power, a reliable planetary drive axle, 3-speed transmission and dual drive tires, provide superior performance and durability. Trucks are equipped with Clark T12,000 series 3-speed powershift transmissions and powerful Perkins diesel or GM LPG engines. These trucks are supplied with a high level of standard features.

## Operator Control & Comfort

The CMP 50 Series trucks incorporate an isolated operator cell supported on rubber mounts to reduce vibration and sound transmission to the operator seat and controls. Two open steps enable easy access to the cabin, from either side. A rubber floor mat makes footing secure. Hood-mounted hydraulic control levers for operator convenience. The Electronic Gear Selector (EGS) provides "finger tip" directional control; speed range is selected by rotating the grip on the control. Forward-reverse shifts are prevented until truck has slowed to 1 mph. Downshifts that would overspeed the engine are also prevented. Two-pedal inch-brake system provides excellent operator control and comfort. Left pedal is for inch and brake operation; right pedal for brakes only. Equipped with a legendary Clark safety seat with shoulder restraints, adjustable and fold-down back rest, molded bolsters for comfort and support, six inches (150 mm) fore/aft adjustment, a retractable seat belt and an operator manual in the seat pocket. The tilt steering wheel, with four turns lock-to-lock, can be secured at any position within its range of travel. The high visibility upright and overhead guard improve operator vision during travel and stacking operations. The instrument panel includes indicator lights for engine oil pressure, transmission oil pressure and temperature, alternator charge, diesel preheat, parking brake applied, turn signals and panel test light. Gauges are provided for engine coolant temperature and fuel level. A five-digit hour meter is standard.

## Diesel Engine

An EPA compliant Perkins model 1104C-44, 4.4L 4-cylinder engine with automatic engine shutdown to protect the engine from high engine coolant temperature or low engine oil pressure. Glow-plug start iron block and cylinder head, 5 main bearing crankshaft and an internal dynamic balancer system that smoothes engine vibration. Valve guides, exhaust valve seals and dry type cylinder sleeves are replaceable. New generation design incorporates low emission levels; low smoke, fuel efficient direct fuel injection and manifold type cold start system. Vertical exhaust is standard.

## LPG Engine

An improved GM Vortec model 4300LT, 4.3L, V6 engine with hardened intake and exhaust valves and seats, a dynamic balancer system for reduced vibration, serpentine accessory belt drive and an EPA compliant LPG fuel system with diagnostics. An automatic engine shut-down system protects the engine from high engine coolant temperature or low engine oil pressure. Engine Accessories/Capacities: Trucks are 12-volt negative ground. Starters are equipped with heavy-duty clutch and anti-restart system. Batteries are 860 CCA at 0°F (-18 °C). Engines are protected with heavy duty air cleaners, air restriction indicators and pre-cleaners mounted above the rear hood. Cooling system capacity is 16 qts. (16.9 L), crankcase capacity is 2 gals. (7.6 L); and fuel tank capacity is 18 gal. (68 L). Service inspection and access is facilitated by a rear-hinged clamshell hood with gas struts and a floorplate which is easily removed without tools. The pivoted rear hood allows access to the radiator and rear lift eyes. The radiator can be serviced or changed without counterweight removal.

## Transmission

Clark T12,000 Series three-speed powershift transmission designed for reliability under maximum load and severe operating conditions. The plate-type transmission cooler is located in the radiator. Clark EGS electric shift control provides controlled shift

operation and protects the transmission from damage. Mechanical linkage is eliminated. Transmission clutch packs incorporate hydraulic modulation and cushioning systems to provide smooth engagement and protect internal components under rapid direction reversals. Highly accessible transaxle control, auxiliary gear drive for the hydraulic pump and spin-on full-flow lubricant filter simplify service.

## Drive Axle

A heavy duty planetary drive axle improves tractive effort as maximum wheel torque is developed at the drive wheels, eliminating axleshaft wind-up and reducing loads on other drive components.

## Brakes

Hydraulically operated service brakes actuate self-adjusting drum and shoe assemblies at the drive wheels. Brakes can be actuated from either left or right foot pedals. Left foot pedal also provides inching control. Disc/caliper-type parking brake on the transmission is left hand-operated, and operator adjustable. A brake system reservoir is easily accessed on the front cowl.

## Steering

A heavy fabricated steer axle incorporates an integral double-acting steer cylinder providing equal steering rate. The rugged, durable linkage has sealed spherical bearings, "double shear" pivot pins, grease fittings and no adjustments are required. Single-piece steer knuckles supported by tapered roller bearings provide high durability with low maintenance requirements. The axle is mounted in "silent block" cushion mounts that absorb shock, improve comfort, and require no maintenance.

## Hydraulic System

A tandem hydraulic pump is transmission driven, providing both durability and accessibility. Full-flow filter is located in the hydraulic tank providing continuous filtration. Hydraulic tank cover incorporates return line fittings, dipstick, and breather filter connection. The pressure compensated main hydraulic valve has adjustable flow controls and pressure relief for optimum attachment operation, ability to operate lift, tilt and auxiliary functions simultaneously, and improved spool feathering. Addition of extra auxiliary functions is facilitated by the sectional valve design. Integral-with-frame hydraulic tank dissipates hydraulic oil heat. Fluid capacity 29 U.S. gals. (110 L).

## Upright Assembly

Clark high-visibility uprights are available in two-stage and triple-stage designs. Clark designed rails are nested and interlocked with sealed, canted rollers to minimize deflection. The nested rail design and efficient internal hosing allow maximum visibility. Hydraulic cushioning valves provide silent staging of the rails during lifting and lowering. Upright rails feature negative rail drop enabling rollers to be easily accessed for service. Pin-mount carriages have six rail rollers and two side thrust rollers to protect against unbalanced loads. Tilt cylinders incorporate spherical bushings at both ends to extend seal life by minimizing axial cylinder loads. Lowering speed is controlled under all conditions by a load lowering valve and lift cylinder mounted flow control valves. A hydraulic counterbalance valve prevents tilt drift. Shaft type forks are upset forged and have adjustable fork locks.

## Additional Features

Color is high visibility Clark Green with non-glare matte black trim and white wheels. Standard features include two headlights, brake lights, tail lights, turn signals, single auxiliary valve, hood-mounted valve levers, lift eyes on upright and rear frame, integral pin-type carriage, high-mounted precleaner on diesel and LPG, open-core radiator, vertical exhaust with diesel engine, dual drive tires, and recessed town pin. Operator manual attached in back of seat. Clark's *Employer's Guide to Material Handling Safety* and operator safety video are provided with truck. Contact a Clark representative for additional information.

## Upright Table

Maximum Fork Height		Overall Height Lowered		Free Lift		Standard <sup>1</sup> Tilt Spec
in	mm	in	mm	in	mm	B°/F°
<b>CMP50/60/70/75s</b>						
<b>Standard</b>						
98	2500	88.6	2250	4.3	110	10/15
106	2700	92.5	2350	4.3	110	10/15
118	3000	98.4	2500	4.3	110	10/15
130	3300	104.3	2650	4.3	110	10/15
• 137	3500	108.3	2750	4.3	110	10/15
145	3700	112.2	2850	4.3	110	10/15
157	4000	118.1	3000	4.3	110	10/10
177	4500	128.0	3250	4.3	110	10/10
196	5000	137.8	3500	4.3	110	10/10
216	5500	147.6	3750	4.3	110	10/10
236	6000	165.4	4200	4.3	110	6/6
252	6400	173.2	4400	4.3	110	6/6

<b>CMP50/60/70/75s</b>						
<b>Triple Stage</b>						
157	4000	94.9	2410	48.8	1240	10/10
177	4500	101.6	2580	55.5	1410	10/10
• 193	4900	106.9	2715	60.6	1540	10/10
244	6200	128.8	3272	82.7	2100	6/6
275	7000	139.4	3540	93.1	2365	6/6
315	8000	152.4	3872	106.3	2700	6/6

- Indicates preferred common specification.
- <sup>1</sup> Standard Tilt shown. Contact a Clark representative for information on optional tilt.

## Grade Clearance

Model	A%	B%
CMP 50	41	43
CMP 60	38	43
CMP 70	34	43
CMP 75S	31	43

## Notes

Production engines and driveline components may vary in output and/or efficiency by ±5%. The performance shown represents nominal values which may be obtained under typical operating conditions of a machine.

Clark products and specifications are subject to change without notice.

© Clark Material Handling Company 2005.

## ANSI and Insurance Classification

Standard truck meets all applicable mandatory requirements of ANSI-B56.1 Safety Standard for Powered Industrial Trucks and Underwriters Laboratories requirements as to fire hazard only for D and LP classifications. For further information contact a Clark representative.

## For Your Safety

Before operating a lift truck, an operator must:

- **Be trained and authorized**
- **Read and understand the operator's manual**
- **Not operate a faulty lift truck**
- **Not repair a lift truck unless trained and authorized**
- **Have the overhead guard and load backrest extension in place**

During operation, a lift truck operator must:

- **Wear a seat belt**
- **Keep entire body inside truck cab**
- **Never carry passengers or lift people**
- **Keep truck away from people and obstructions**
- **Travel with lift mechanism as low as possible and tilted back**

To park a lift truck, an operator must:

- **Completely lower forks or attachments**
- **Shift into neutral**
- **Turn key off**
- **Set parking brake**
- **Contact your Clark dealer for operator training information.**

**North America CMHC**  
**Worldwide Headquarters**  
 700 Enterprise Drive  
 Lexington, KY 40510  
**866-252-5275**  
[www.clarkmhc.com](http://www.clarkmhc.com)

your authorized CLARK dealer is: