

IC-PNEUMATIC

Pneumatic Tire Lift Trucks
Diesel/LPG

CMP40
CMP45
CMP50S

8,000 lbs 4000 kg
9,000 lbs 4500 kg
10,000 lbs 5000 kg

CMP40/45/50S

M Series



CLARK[®]
BUILT TO LAST.[®]

w w w . c l a r k m h c . c o m

For corresponding data see Specification Chart.

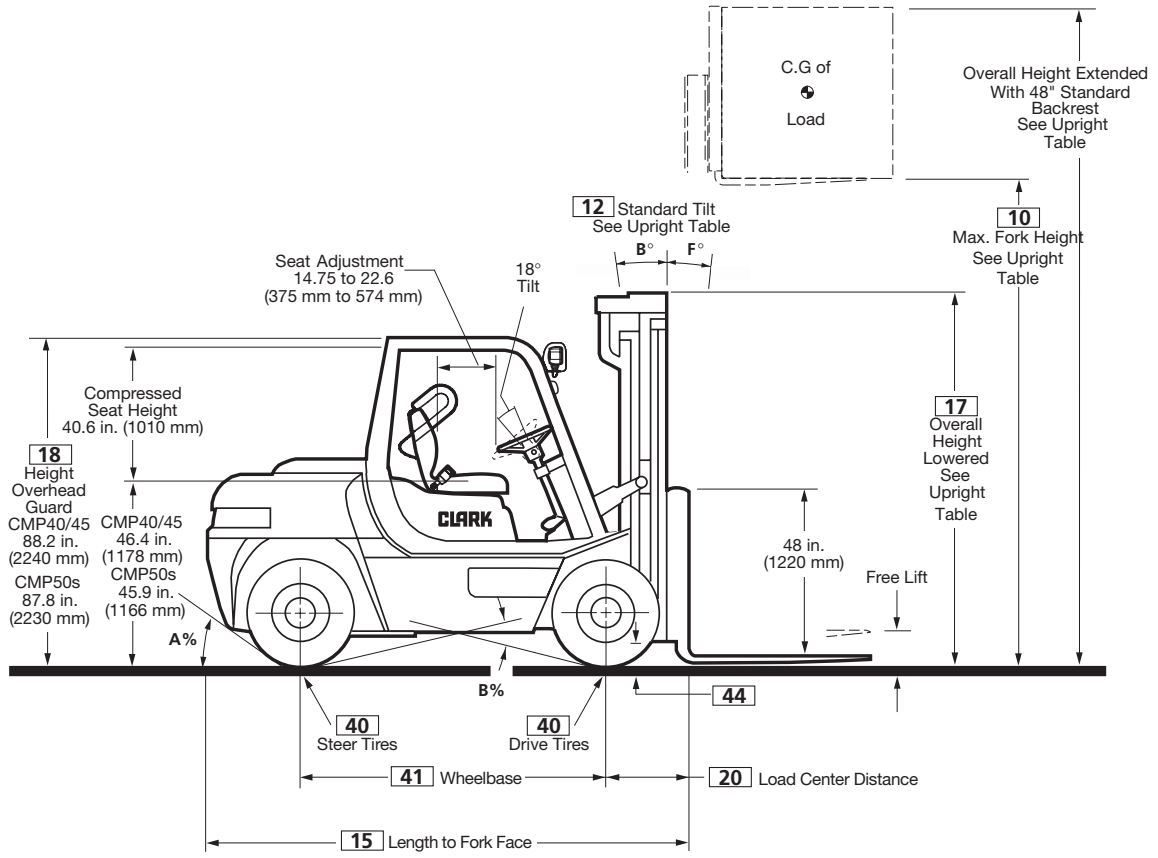

CMP40/45/50S

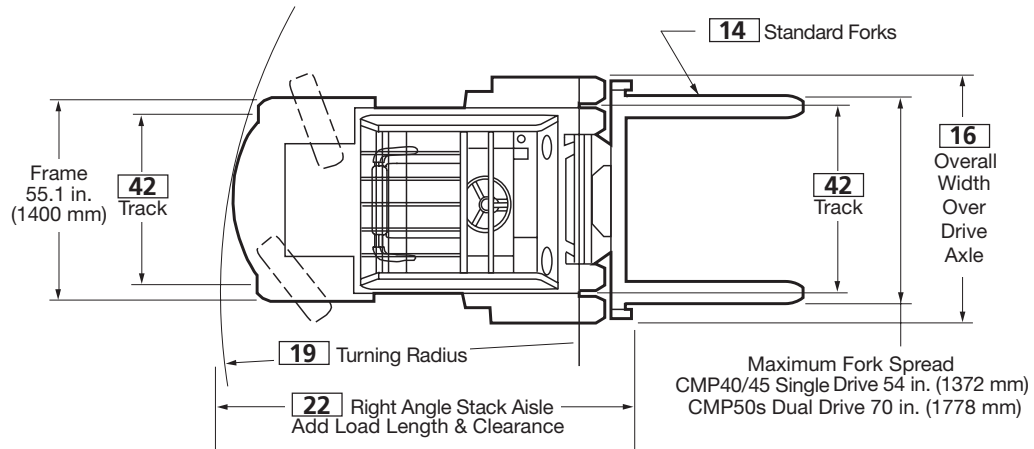

General Information	1	Manufacturer		Clark	Clark	Clark	
	2	Model	Manufacturer's Designation	CMP40	CMP45	CMP50S	
	3	Load Capacity	lbs (kg)	8000 (4000)	9000 (4500)	10,000 (5000)	
	4	Load Center	Fork Face Load CG	in (mm)	24 (500)	24 (500)	24 (500)
	5	Drive Unit	Type	Diesel	Diesel	Diesel	
		Drive Tires	Type	Single Drive	Single Drive	Single Drive	
	6	Operator Type		Rider Counterbalanced	Rider Counterbalanced	Rider Counterbalanced	
	7	Tire Type		Pneumatic	Pneumatic	Pneumatic	
8	Wheels (x=driven)	Front / Rear	2x / 2	2x / 2	2x / 2		
Basic Dimensions	9	Upright ^{1,2}	Maximum Fork Height, Full Capacity	in (mm)	169 (4295)	157 (3990)	157 (3990)
	10		Lift Height (preferred standard upright)	in (mm)	130 (3300)	130 (3300)	130 (3300)
	11		Free Lift	in (mm)	3.9 (100)	3.9 (100)	3.9 (100)
	12	Upright Tilt	Back / Forward (See Upright Table)	degrees	10 / 8	10 / 8	10 / 8
	14	Fork	Std. Fork Size (T x W x L)	in (mm)	2x5x48 (50x122x1220)	2x5x48 (50x122x1220)	2x6x48 (50x150x1220)
	15	Overall Dimensions	Length to Fork Face	in (mm)	121.6 (3090)	123.2 (3130)	124.8 (3170)
	16		Width over drive axle	in (mm)	61 (1550)	61 (1550)	61 (1550)
			Height, Upright Lowered	in (mm)	94.7 (2405)	94.7 (2405)	94.7 (2405)
			Height, Upright Extended w/load backrest	in (mm)	178 (4520)	178 (4520)	178 (4520)
	18		Height, overhead guard	in (mm)	88.9 (2257)	88.9 (2257)	88.9 (2257)
	19	Turning Radius		in (mm)	111.4 (2830)	113 (2870)	114.2 (2900)
	20	Load Center Distance	Center of Drive Axle to Fork Face	in (mm)	22.4 (570)	22.4 (570)	22.4 (570)
22	Right Angle Stack Aisle	Add Load Length and Clearance	in (mm)	133.8 (3400)	135.4 (3440)	136.6 (3470)	
Performance^{1,3}	23	Stability	According to ANSI B56.1		Yes	Yes	Yes
	24	Speeds	Travel Speed, Max w/ Load	mph (kph)	11.7 (18.8)	11.6 (18.7)	11.7 (18.9)
	25		Travel Speed, Max w/o Load	mph (kph)	12.3 (19.9)	12.3 (19.9)	12.4 (20.0)
			Speed on grade				
			5%, loaded	mph (kph)	10.1 (16.3)	10.1 (16.3)	9.9 (16.0)
			10%, loaded	mph (kph)	6.2 (10.0)	6.1 (9.8)	5.2 (8.4)
			15%, loaded	mph (kph)	2.9 (4.7)	2.3 (3.7)	0.9 (1.5)
	26	Lift Speeds, Loaded/Empty	Standard upright	fpm (ms)	86/95 (.44/.48)	83/95 (.42/.48)	79/95 (.40/.48)
	28		Triple Stage upright	fpm (ms)	86/95 (.44/.48)	83/95 (.42/.48)	79/95 (.40/.48)
	29	Lower Speeds, Loaded/Empty	All uprights	fpm (ms)			
30	Drawbar Pull, Maximum	With Load	lbs (N)	7,577 (33705)	7,608 (33843)	7,462 (33196)	
31		Without Load	lbs (N)	3,933 (17446)	3,844 (17103)	3,818 (16985)	
32	Gradeability	At 1 mph (1.6 kph) with load (low range)	%	33.5	31.2	27.9	
		Maximum with/without load	%	37.0/21.7	34.3/20.6	30.7/19.3	
Weights¹	34	Service weight		lbs (kg)	14,061 (6378)	14,563 (6606)	15,472 (7018)
	35	Axle loading	With Load, Front	lbs (kg)	18,547 (8413)	20,130 (9131)	21,783 (9881)
	36		With Load, Rear	lbs (kg)	3,229 (1465)	3,251 (1475)	3,608 (1637)
	37		W/O Load, Front	lbs (kg)	6,598 (2993)	6,472 (2936)	6,419 (2912)
	38		W/O Load, Rear	lbs (kg)	7,462 (3385)	8,090 (3670)	9,052 (4106)
Chassis	39	Tires	Number, Front / Rear		2 / 2	2 / 2	2x / 2
	40		Size, Front	in	8.25 x 15 - 14 ply rating	8.25 x 15 - 16 ply rating	300 x 15-18 ply rating
			Size, Rear	in	7.00 x 12 - 14 ply rating	7.00 x 12 - 14 ply rating	7.00 x 12 - 14 ply rating
	41	Wheelbase		in (mm)	76.8 (1950)	76.8 (1950)	76.8 (1950)
	42	Track	Front/Rear	in (mm)	51.0/45.3 (1295/1150)	51.0/45.3 (1295/1150)	49.0/45.3 (1245/1150)
	44	Ground Clearance	Minimum / at Center of Wheelbase	in (mm)	6.8/9.0 (173/230)	6.8/9.0 (173/230)	6.8/9.0 (173/230)
	46	Service Brake	Type		Wet Disc	Wet Disc	Wet Disc
	47	Parking Brake	Actuation		Lever	Lever	Lever
	Steering	Type		Hydrostatic	Hydrostatic	Hydrostatic	
Drive Line	49	Engine	Manufacturer / Model		Perkins / 1104C.44	Perkins / 1104C.44	Perkins / 1104C.44
	51		Rated Output ²	HP/KW @ rpm	82.8/61.5 @ 2200	82.8/61.5 @ 2200	82.8/61.5 @ 2200
			Torque	lb-ft/Nm @ rpm	223/303 @ 1400	223/303 @ 1400	223/303 @ 1400
	52		Speed, max Governed	rpm	2400	2400	2400
	53		Cylinders / Displacement	cu. in.-Liters	4 / 268-4.4	4 / 268-4.4	4 / 268-4.4
	54	Transmission	Manufacturer / Type, Speeds F/R		Powershift, 2 / 2	Powershift, 2 / 2	Powershift, 2 / 2
57	Hydraulic Pressure	For Attachments	psi (bar)	2000 (137)	2000 (137)	2000 (137)	
58	Sound Level	Avg. at Operator's Ear per ASME B56.11.5	dB(A)	80	80	80	

Notes: 1 See Upright Table
3 Engines rated per SAE J1349.

2 Specifications are given for the truck with the standard upright noted in line 10.

SPECIFIC ATTIONS

General Information	1	Manufacturer		Clark	Clark	Clark	
	2	Model	Manufacturer's Designation	CMP40	CMP45	CMP50S	
	3	Load Capacity	lbs (kg)	8000 (4000)	9000 (4500)	10,000 (5000)	
	4	Load Center	Fork Face Load CG	in (mm)	24 (500)	24 (500)	24 (500)
	5	Drive Unit	Type	LPG	LPG	LPG	
		Drive Tires	Type	Single Drive	Single Drive	Single Drive	
	6	Operator Type		Rider Counterbalanced	Rider Counterbalanced	Rider Counterbalanced	
	7	Tire Type		Pneumatic	Pneumatic	Pneumatic	
8	Wheels (x=driven)	Front / Rear	2x / 2	2x / 2	2x / 2		
Basic Dimensions	9	Upright ²	Maximum Fork Height, Full Capacity	in (mm)	169 (4295)	157 (3990)	157 (3990)
	10		Lift Height (preferred standard upright)	in (mm)	130 (3300)	130 (3300)	130 (3300)
	11		Free Lift	in (mm)	3.9 (100)	3.9 (100)	3.9 (100)
	12	Upright Tilt	Back / Forward (See Upright Table)	degrees	10 / 8	10 / 8	10 / 8
	14	Fork	Std. Fork Size (T x W x L)	in (mm)	2x5x48 (50x122x1220)	2x5x48 (50x122x1220)	2x6x48 (50x150x1220)
	15	Overall Dimensions	Length to Fork Face	in (mm)	121.6 (3090)	123.2 (3130)	124.8 (3170)
	16		Width over drive axle	in (mm)	61 (1550)	61 (1550)	61 (1550)
			Height, Upright Lowered	in (mm)	94.7 (2405)	94.7 (2405)	94.7 (2405)
			Height, Upright Extended w/load backrest	in (mm)	178 (4520)	178 (4520)	178 (4520)
	18		Height, overhead guard	in (mm)	88.9 (2257)	88.9 (2257)	88.9 (2257)
	19	Turning Radius		in (mm)	111.4 (2830)	113 (2870)	114.2 (2900)
	20	Load Center Distance	Center of Drive Axle to Fork Face	in (mm)	22.4 (570)	22.4 (570)	22.4 (570)
22	Right Angle Stack Aisle	Add Load Length and Clearance	in (mm)	133.8 (3400)	135.4 (3440)	136.6 (3470)	
Performance ^{1,3}	23	Stability	According to ANSI B56.1		Yes	Yes	Yes
	24	Speeds	Travel Speed, Max w/ Load	mph (kph)	13.1 (21.1)	13.0 (20.9)	13.0 (20.9)
	25		Travel Speed, Max w/o Load	mph (kph)	13.8 (22.3)	13.8 (22.3)	13.8 (22.3)
			Speed on grade	mph (kph)	12.4 (20.0)	11.8 (19.0)	10.9 (17.6)
				mph (kph)	6.9 (11.0)	6.7 (10.8)	6.2 (10.0)
				mph (kph)	4.8 (7.1)	4.3 (6.8)	3.8 (6.1)
	26	Lift Speeds, Loaded/Empty	Standard upright	fpm (ms)	86/95 (.44/.48)	83/95 (.42/.48)	79/95 (.40/.48)
	28		Triple Stage upright	fpm (ms)	86/95 (.44/.48)	83/95 (.42/.48)	79/95 (.40/.48)
	29	Lower Speeds, Loaded/Empty	All uprights	fpm (ms)	93/87 (.47/.44)	93/87 (.47/.44)	93/87 (.47/.44)
30	Drawbar Pull, Maximum	With Load	lbs (N)	7,400 (32920)	7,450 (33181)	7,360 (32740)	
31		Without Load	lbs (N)	3,425 (15242)	3,350 (14904)	3,300 (14720)	
32	Gradeability	At 1 mph (1.6 kph) with load (low range)	%	30	28	25	
		Maximum with / without load	%	33/21	31/20	28/18	
Weights ¹	34	Service weight	lbs (kg)	14,061 (6378)	14563 (6606)	15,472 (7018)	
	35	Axle loading	With Load, Front	lbs (kg)	19,431 (8816)	20,910 (9484)	22,461 (10188)
	36		With Load, Rear	lbs (kg)	2,630 (1192)	2,653 (1203)	3,011 (1366)
	37		W/O Load, Front	lbs (kg)	6,598 (2993)	6,472 (2936)	6,419 (2912)
	38		W/O Load, Rear	lbs (kg)	7,463 (3385)	8,091 (3670)	9,053 (4106)
Chassis	39	Tires	Number, Front / Rear		2 / 2	2 / 2	2x / 2
	40		Size, Front	in	8.25 x 15 - 14 ply rating	8.25 x 15 - 16 ply rating	300 x 15-18 ply rating
			Size, Rear	in	7.00 x 12 - 14 ply rating	7.00 x 12 - 14 ply rating	7.00 x 12 - 14 ply rating
	41	Wheelbase		in (mm)	76.8 (1950)	76.8 (1950)	76.8 (1950)
	42	Track	Front / Rear	in (mm)	51.0/45.3 (1295/1150)	51.0/45.3 (1295/1150)	49.0/45.3 (1245/1150)
	44	Ground Clearance	Minimum / at Center of Wheelbase	in (mm)	6.8/9.0 (173/230)	6.8/9.0 (173/230)	6.8/9.0 (173/230)
	46	Service Brake	Type		Wet Disc	Wet Disc	Wet Disc
	47	Parking Brake	Actuation		Lever	Lever	Lever
		Steering	Type		Hydrostatic	Hydrostatic	Hydrostatic
Drive Line	49	Engine	Manufacturer / Model		GM/Vortec /4300LT	GM/Vortec /4300LT	GM/Vortec /4300LT
	51		Rated Output ²	HP/kW @ rpm	93/69 @ 2400	93/69 @ 2400	93/69 @ 2400
			Torque	lb-ft/Nm @ rpm	235/318 @ 2000	235/318 @ 2000	235/318 @ 2000
	52		Speed, max Governed	rpm	2650	2650	2650
	53		Cylinders / Displacement	cu. in.-Liters	6 / 262-4.3	6 / 262-4.3	6 / 262-4.3
	54	Transmission	Manufacturer / Type, Speeds F/R		Powershift, 2 / 2	Powershift, 2 / 2	Powershift, 2 / 2
	57	Hydraulic Pressure	For Attachments	psi (bar)	2000 (137)	2000 (137)	2000 (137)
58	Sound Level	Avg. at Operator's Ear per ASME B56.11.5	dB(A)	80	80	80	

² Specifications are given for the truck with the standard upright noted in line 10.

¹ See Upright Table.
³ Engines rated per SAE J1349.

Notes:

Notes: 1 See Upright Table.
3 Engines rated per SAE J1349.

General Information				Clark	Clark	Clark
1	Manufacturer			Clark	Clark	Clark
2	Model	Manufacturer's Designation		CMP40	CMP45	CMP50S
3	Load Capacity		lbs (kg)	8000 (4000)	9000 (4500)	10,000 (5000)
4	Load Center	Fork Face Load CG	in (mm)	24 (500)	24 (500)	24 (500)
5	Drive Unit	Type		Diesel	Diesel	Diesel
	Drive Tires	Type		Dual Drive	Dual Drive	Dual Drive
6	Operator Type			Rider Counterbalanced	Rider Counterbalanced	Rider Counterbalanced
7	Tire Type			Pneumatic	Pneumatic	Pneumatic
8	Wheels (x=driven)	Front / Rear		4x / 2	4x / 2	4x / 2
Basic Dimensions						
9	Upright ^{1,2}	Maximum Fork Height, Full Capacity	in (mm)	169 (4295)	157 (3990)	157 (3990)
10		Lift Height (preferred standard upright)	in (mm)	130 (3300)	130 (3300)	130 (3300)
11		Free Lift	in (mm)	3.9 (100)	3.9 (100)	3.9 (100)
12	Upright Tilt	Back / Forward (See Upright Table)	degrees	10 / 8	10 / 8	10 / 8
14	Fork	Std. Fork Size (T x W x L)	in (mm)	2x5x48 (50x122x1220)	2x5x48 (50x122x1220)	2x6x48 (50x150x1220)
15	Overall Dimensions	Length to Fork Face	in (mm)	122.0 (3100)	123.6 (3140)	125.2 (3180)
16		Width over drive axle	in (mm)	74.8 (1900)	74.8 (1900)	74.8 (1900)
		Height, Upright Lowered	in (mm)	93.9 (2385)	93.9 (2385)	93.9 (2385)
		Height, Upright Extended w/load backrest	in (mm)	178 (4520)	178 (4520)	178 (4520)
18		Height, overhead guard	in (mm)	87.7 (2227)	87.7 (2227)	87.7 (2227)
19	Turning Radius		in (mm)	111.4 (2830)	113 (2870)	114.2 (2900)
20	Load Center Distance	Center of Drive Axle to Fork Face	in (mm)	22.8 (580)	22.8 (580)	22.8 (580)
22	Right Angle Stack Aisle	Add Load Length and Clearance	in (mm)	134.2 (3410)	134.2 (3410)	134.2 (3410)
Performance ^{1,3}						
23	Stability	According to ANSI B56.1		Yes	Yes	Yes
24	Speeds	Travel Speed, Max w/ Load	mph (kph)	11.1 (17.8)	11.0 (17.7)	10.9 (17.6)
25		Travel Speed, Max w/o Load	mph (kph)	11.6 (18.7)	11.6 (18.7)	11.6 (18.7)
		Speed on grade				
		5%, loaded	mph (kph)	10.1 (16.2)	9.9 (15.9)	9.6 (15.5)
		10%, loaded	mph (kph)	6.6 (10.6)	6.0 (9.6)	5.2 (8.3)
		15%, loaded	mph (kph)	3.0 (4.9)	2.2 (3.5)	1.1 (1.7)
26	Lift Speeds, Loaded/Empty	Standard upright	fpm (ms)	86/95 (.44/.48)	83/95 (.42/.48)	79/95 (.40/.48)
28		Triple Stage upright	fpm (ms)	86/95 (.44/.48)	83/95 (.42/.48)	79/95 (.40/.48)
29	Lower Speeds, Loaded/Empty	All uprights	fpm (ms)	(.47/.47)	(.47/.47)	(.47/.47)
30	Drawbar Pull, Maximum	With Load	lbs (N)	8,009 (35628)	8,024 (35696)	8,031 (35726)
31		Without Load	lbs (N)	4,305 (19,152)	4,228 (18809)	4,195 (18662)
32	Gradeability	At 1 mph (1.6 kph) with load (low range)	%	33.3	30.9	28.3
		Maximum with/without load	%	38.3/23.1	35.5/22.0	32.5/20.7
Weights ¹						
34	Service weight		lbs (kg)	14,601 (6623)	15,103 (6851)	16,012 (7263)
35	Axle loading	With Load, Front	lbs (kg)	19,213 (8715)	20,800 (9435)	22,460 (10,188)
36		With Load, Rear	lbs (kg)	3,104 (1408)	3,121 (1416)	3,472 (1575)
37		W/O Load, Front	lbs (kg)	7,224 (3277)	7,098 (3220)	7,045 (3196)
38		W/O Load, Rear	lbs (kg)	7,376 (3346)	8,004 (3,631)	8,966 (4067)
Chassis						
39	Tires	Number, Front / Rear		4 / 2	4 / 2	4 / 2
40		Size, Front	in	7.50 x 15 - 12 ply rating	7.50 x 15 - 12 ply rating	7.50 x 15 - 12 ply rating
		Size, Rear	in	7.00 x 12 - 14 ply rating	7.00 x 12 - 14 ply rating	7.00 x 12 - 14 ply rating
41	Wheelbase		in (mm)	76.8 (1950)	76.8 (1950)	76.8 (1950)
42	Track	Front / Rear	in (mm)	56.0/45.3 (1423/1150)	56.0/45.3 (1423/1150)	56.0/45.3 (1423/1150)
44	Ground Clearance	Minimum / at Center of Wheelbase	in (mm)	5.9/8.0 (150/205)	5.9/8.0 (150/205)	5.9/8.0 (150/205)
46	Service Brake	Type		Wet Disc	Wet Disc	Wet Disc
47	Parking Brake	Actuation		Lever	Lever	Lever
	Steering	Type		Hydrostatic	Hydrostatic	Hydrostatic
Drive Line						
49	Engine	Manufacturer / Model		Perkins / 1104C.44	Perkins / 1104C.44	Perkins / 1104C.44
51		Rated Output ²	HP/KW @ rpm	82.8/61.5 @ 2200	82.8/61.5 @ 2200	82.8/61.5 @ 2200
		Torque	lb-ft/Nm @ rpm	223/303 @ 1400	223/303 @ 1400	223/303 @ 1400
52		Speed, max Governed	rpm	2400	2400	2400
53		Cylinders / Displacement	cu. in.-Liters	4 / 268-4.4	4 / 268-4.4	4 / 268-4.4
54	Transmission	Manufacturer / Type, Speeds F/R		Powershift, 2 / 2	Powershift, 2 / 2	Powershift, 2 / 2
57	Hydraulic Pressure	For Attachments	psi (bar)	2000 (137)	2000 (137)	2000 (137)
58	Sound Level	Avg. at Operator's Ear per ASME B56.11.5	dB(A)	80	80	80

2 Specifications are given for the truck with the standard upright noted in line 10.

SPECIFICATIONS

General Information				Clark	Clark	Clark
1	Manufacturer			Clark	Clark	Clark
2	Model	Manufacturer's Designation		CMP40	CMP45	CMP50S
3	Load Capacity		lbs (kg)	8000 (4000)	9000 (4500)	10,000 (5000)
4	Load Center	Fork Face Load CG	in (mm)	24 (500)	24 (500)	24 (500)
5	Drive Unit	Type		LPG	LPG	LPG
	Drive Tires	Type		Dual Drive	Dual Drive	Dual Drive
6	Operator Type			Rider Counterbalanced	Rider Counterbalanced	Rider Counterbalanced
7	Tire Type			Pneumatic	Pneumatic	Pneumatic
8	Wheels (x=driven)	Front / Rear		4x / 2	4x / 2	4x / 2
Basic Dimensions						
9	Upright ^{1,2}	Maximum Fork Height, Full Capacity	in (mm)	169 (4295)	157 (3990)	157 (3990)
10		Lift Height (preferred standard upright)	in (mm)	130 (3300)	130 (3300)	130 (3300)
11		Free Lift	in (mm)	3.9 (100)	3.9 (100)	3.9 (100)
12	Upright Tilt	Back / Forward (See Upright Table)	degrees	10 / 8	10 / 8	10 / 8
14	Fork	Std. Fork Size (T x W x L)	in (mm)	2x5x48 (50x122x1220)	2x5x48 (50x122x1220)	2x6x48 (50x150x1220)
15	Overall Dimensions	Length to Fork Face	in (mm)	122.0 (3100)	123.6 (3140)	125.2 (3180)
16		Width over drive axle	in (mm)	74.8 (1900)	74.8 (1900)	74.8 (1900)
		Height, Upright Lowered	in (mm)	93.9 (2385)	93.9 (2385)	93.9 (2385)
		Height, Upright Extended w/load backrest	in (mm)	178 (4520)	178 (4520)	178 (4520)
18		Height, overhead guard	in (mm)	87.7 (2227)	87.7 (2227)	87.7 (2227)
19	Turning Radius		in (mm)	111.4 (2830)	113 (2870)	114.2 (2900)
20	Load Center Distance	Center of Drive Axle to Fork Face	in (mm)	22.8 (580)	22.8 (580)	22.8 (580)
22	Right Angle Stack Aisle	Add Load Length and Clearance	in (mm)	134.2 (3410)	134.2 (3410)	134.2 (3410)
Performance ^{1,3}						
23	Stability	According to ANSI B56.1		Yes	Yes	Yes
24	Speeds	Travel Speed, Max w/ Load	mph (kph)	12.4 (19.9)	12.3 (19.8)	12.2 (19.7)
25		Travel Speed, Max w/o Load	mph (kph)	13.3 (21.4)	13.3 (21.4)	13.3 (21.4)
		Speed on grade	mph (kph)	11.8 (18.9)	11.5 (18.6)	10.7 (17.2)
			mph (kph)	6.5 (10.5)	6.5 (10.4)	6.1 (9.8)
			mph (kph)	4.7 (7.6)	4.2 (6.8)	3.7 (6.0)
26	Lift Speeds, Loaded/Empty	Standard upright	fpm (ms)	106/116 (.54/.49)	104/116 (.53/.59)	102/116 (.52/.59)
28		Triple Stage upright	fpm (ms)	106/116 (.54/.49)	104/116 (.53/.59)	102/116 (.52/.59)
29	Lower Speeds, Loaded/Empty	All uprights	fpm (ms)	93/87 (.47/.44)	93/87 (.47/.44)	93/87 (.47/.44)
30	Drawbar Pull, Maximum	With Load	lbs (N)	7,700 (34241)	7,700 (34241)	7,700 (34241)
31		Without Load	lbs (N)	3,750 (19283)	3,675 (16399)	3,650 (16308)
32	Gradeability	At 1 mph (1.6 kph) with load (low range)	%	31	28	26
		Maximum with / without load	%	34/22	32/21	29/19
Weights ¹						
34	Service weight		lbs (kg)	14,601 (6623)	15,103 (6851)	16,012 (7263)
35	Axle loading	With Load, Front	lbs (kg)	20074 (9105)	21,554 (9777)	23,108 (10482)
36		With Load, Rear	lbs (kg)	2,527 (1146)	2,549 (1156)	2,904 (1317)
37		W/O Load, Front	lbs (kg)	7,225 (3277)	7,093 (3220)	7,046 (3196)
38		W/O Load, Rear	lbs (kg)	7,376 (3346)	8,005 (3631)	8,966 (4067)
Chassis						
39	Tires	Number, Front / Rear		4 / 2	4 / 2	4 / 2
40		Size, Front	in	7.50 x 15 - 12 ply rating	7.50 x 15 - 12 ply rating	7.50 x 15 - 12 ply rating
		Size, Rear	in	7.00 x 12 - 14 ply rating	7.00 x 12 - 14 ply rating	7.00 x 12 - 14 ply rating
41	Wheelbase		in (mm)	76.8 (1950)	76.8 (1950)	76.8 (1950)
42	Track	Front/Rear	in (mm)	56.0/45.3 (1423/1150)	56.0/45.3 (1423/1150)	56.0/45.3 (1423/1150)
44	Ground Clearance	Minimum / at Center of Wheelbase	in (mm)	5.9/8.0 (150/205)	5.9/8.0 (150/205)	5.9/8.0 (150/205)
46	Service Brake	Type		Wet Disc	Wet Disc	Wet Disc
47	Parking Brake	Actuation		Lever	Lever	Lever
	Steering	Type		Hydrostatic	Hydrostatic	Hydrostatic
Drive Line						
49	Engine	Manufacturer / Model		GM/Vortec 4300LT	GM/Vortec 4300LT	GM/Vortec 4300LT
51		Rated Output ²	HP/kW @ rpm	93/69 @ 2400	93/69 @ 2400	93/69 @ 2400
		Torque	lb-ft/Nm @ rpm	235/318 @ 2000	235/318 @ 2000	235/318 @ 2000
52		Speed, max Governed	rpm	2650	2650	2650
53		Cylinders / Displacement	cu. in.-Liters	6 / 262-4.3	6 / 262-4.3	6 / 262-4.3
54	Transmission	Manufacturer / Type, Speeds F/R		Powershift, 2 / 2	Powershift, 2 / 2	Powershift, 2 / 2
57	Hydraulic Pressure	For Attachments	psi (bar)	2000 (137)	2000 (137)	2000 (137)
58	Sound Level	Avg. at Operator's Ear per ASME B56.11.5	dB(A)	80	80	80

² Specifications are given for the truck with the standard upright noted in line 10.

¹ See Upright Table.
³ Engines rated per SAE J1349.

CLARK CMP 40 SERIES pneumatic tire trucks are designed for wide ranging indoor and outdoor applications in manufacturing, warehousing and distribution. These versatile trucks are equipped with diesel or LPG engines, two-speed powershift transmissions, wet disc brakes, single or dual drive wheels and wide range of optional equipment.

Operator Control & Comfort

The CMP 40 Series trucks incorporate an isolated operator cell supported on rubber mounts that reduce vibration and sound transmission to the operator seat and controls. Low in-frame steps, 18.7 in. (475 mm) high, enable easy access to the cabin from either side. A large floor mat provides secure footing and the rear floorplate is easily removable for maintenance without tools. Hood-mounted hydraulic control levers for operator convenience. The electric directional control lever enables "finger tip" operation of the powershift transaxle; high/low range is selected by lifting/depressing the lever. Two-pedal inch-brake system provides excellent operator control and comfort. Left pedal is for inch and brake operation, right pedal for brakes only. The parking brake lever is left hand operated and adjustable at the handle. When applied, the parking brake electrically prevents driving against the brakes.

Equipped with a legendary Clark safety seat with shoulder restraints, adjustable and fold-down back rest, molded bolsters for comfort and support, six inches (150 mm) fore/aft adjustment, a retractable seat belt and an operator manual in the seat pocket. The tilt steering wheel, with four turns lock-to-lock, can be secured at any position within its range of travel.

The instrument panel includes indicator lights for engine oil pressure, transmission oil pressure and temperature, alternator charge, diesel pre-heat, parking brake applied, turn signals and panel test light. Gauges are provided for engine coolant temperature and fuel level. A five-digit hour meter is standard.

An optional high quality operator cab, designed for comfort, has a heater, front and rear wipers, AM-FM cassette player and two-piece hinged doors.

Diesel Engine

An EPA compliant Perkins model 1104C-44, 4.4L 4-cylinder engine with automatic engine shutdown to protect the engine from high engine coolant temperature or low engine oil pressure. Glow-plug start, iron block and cylinder head, 5 main bearing crankshaft and an internal dynamic balancer system that smoothes engine vibration. Valve guides, exhaust valve seals and dry type cylinder sleeves are replaceable. New generation design incorporates low emission levels, low smoke, fuel efficient direct fuel injection and manifold type cold start system. Vertical exhaust is standard.

LPG Engine

An improved GM Vortec model 4300LT, 4.3L, V6 engine with hardened intake and exhaust valves and seats, a dynamic balancer system for reduced vibration, serpentine accessory belt drive and an EPA compliant LPG fuel system with diagnostics. An automatic engine shut-down system protects the engine from high engine coolant temperature or low engine oil pressure. Engine Accessories/Capacities: Trucks are 12-volt negative ground. Starters are equipped with heavy-duty clutch and anti-restart system. Batteries are 800 CCA at 0°F (-18 °C). Engines are protected with heavy duty air cleaners, air restriction indicators and pre-cleaners mounted above the rear hood. Cooling system capacity is 16 qts. (16.9 L). Crankcase capacity is 2 gals. (7.6 L); Fuel tank capacity is 17.4 gal. (66 L). Service inspection and access is facilitated by a rear-hinged clamshell hood with gas struts and rear floorplate which is easily removed without tools. The pivoted rear hood allows access to the radiator and rear lift eyes. The radiator can be serviced or changed without counterweight removal. Filters are easily serviced and located to prevent spillage.

Transaxle

SF45 two-speed powershift transaxle is a single unitized driveline designed for reliability under maximum load and severe operating conditions. The transaxle features electric shift control that provides smooth engagement on start-up and on-the-fly shifts between low and high range. Electric shift control eliminates linkage wear and adjustment. A transmission oil cooler located in the engine radiator extends transaxle life. Full-floating drive axle design adds durability as only torsional forces, not truck loads, are transmitted through the axle shafts. Service is enhanced by a readily accessible transaxle control cover and spin-on, full-flow lubricant filter.

Brakes

Hydraulically-operated wet disc brakes provide excellent brake performance and extended brake life. Four brake discs at each wheel are sealed, self-adjusting, immersed and cooled in the axle lubricant, and applied with a hydraulic servo-type power brake valve. Left foot pedal also provides inching control. Disc/caliper-type parking brake on the transmission is left hand-operated and operator adjustable. Brake system reservoir is easily accessed on the front cowl.

Steering

The heavy fabricated steer axle incorporates an integral double-acting steer cylinder providing equal steering rate. The rugged, durable linkage has sealed spherical bearings, "double shear" pivot pins, grease fittings and no adjustments are required. Single-piece steer knuckles supported by tapered roller bearings provide high durability with low maintenance requirements. The axle is mounted in "silent block" cushion mounts that absorb shock, improve comfort, and require no maintenance.

Hydraulic System

An efficient tandem pump system with load-sensing flow control valve is used with a separate pump section for steering. The pressure compensated main hydraulic valve has adjustable flow controls and pressure relief for optimum attachment operation, ability to operate lift, tilt and auxiliary functions simultaneously, and improved spool feathering. Addition of extra auxiliary functions is facilitated by the sectional valve design. The hydraulic tank is integral in the frame for heat dissipation and uses a remote breather. Fluid capacity is 17.1 U.S. gals. (65L).

Upright Assembly

Clark high-visibility uprights are available in two-stage, two-stage HiLo and triple-stage designs. Clark designed rails are nested and interlocked with sealed, canted rollers to minimize deflection. The nested rail design and efficient internal hosing allow maximum visibility. Hydraulic cushioning valves provide silent staging of the rails during lifting and lowering. Upright rails feature negative rail drop enabling rollers to be easily accessed for service. Class III carriages have six rail rollers and two side thrust rollers to protect against unbalanced loads. Tilt cylinders incorporate spherical bushings at both ends to extend seal life by minimizing axial cylinder loads. Lowering speed is controlled under all conditions by a load lowering valve and lift cylinder mounted flow control valves. The pressure compensated main hydraulic valve virtually eliminates lift and tilt cylinder drift. Forks are upset forged and have adjustable locks to maintain desired position. Forks are retained by the load backrest extension.

Additional Features

Standard features include two headlights, single auxiliary valve, internal hosing with sideshifter, hood-mounted valve levers, lift eyes on upright and rear frame, 48 in. (1200mm) high load backrest, recessed tow pin, high pre-cleaner, open-core radiator, vertical exhaust with diesel engine, single drive tires on CMP40/45 and dual drive on CMP50. Color is high visibility Clark Green with non-glare matte black trim and white wheels. Operator manual attached in back of seat. Clark's *Employer's Guide to Material Handling Safety* and operator safety video are provided with truck. Contact a Clark representative for additional information.

Notes

Production engines and driveline components may vary in output and/or efficiency by ±10%. The performance shown represents nominal values which may be obtained under typical operating conditions of a machine. Clark products and specifications are subject to change without notice. © Clark Material Handling Company 2001.

ANSI and Insurance Classification

Standard truck meets all applicable mandatory requirements of ANSI B56.1 Safety Standard for Powered Industrial Trucks and Underwriters Laboratories requirements as to fire hazard only for Type D and L classifications. For further information contact a Clark representative.

For Your Safety

Before operating a lift truck, an operator must:

- **Be trained and authorized**
- **Read and understand the operator's manual**
- **Not operate a faulty lift truck**
- **Not repair a lift truck unless trained and authorized**
- **Have the overhead guard and load backrest extension in place**

During operation, a lift truck operator must:

- **Wear a seat belt**
- **Keep entire body inside truck cab**
- **Never carry passengers or lift people**
- **Keep truck away from people and obstructions**
- **Travel with lift mechanism as low as possible and tilted back**

To park a lift truck, an operator must:

- **Completely lower forks or attachments**
- **Shift into neutral**
- **Turn key off**
- **Set parking brake**
- **Contact your Clark dealer for operator training information.**

Upright Table

Maximum Fork Height in mm	Overall Height ^{1,4}		Free Lift ³		Standard ² Tilt Spec B°/F°	
	Lowered in mm		in mm			
CMP40/45/50s						
Standard						
78	2000	69.2	1758	3.9	100	10/8
90	2300	75.1	1908	3.9	100	10/8
98	2500	79.1	2008	3.9	100	10/8
106	2700	83.0	2108	3.9	100	10/8
118	3000	88.9	2258	3.9	100	10/8
• 130	3300	94.8	2408	3.9	100	10/8
137	3500	98.7	2508	3.9	100	10/8
145	3700	102.7	2608	3.9	100	10/8
157	4000	108.6	2758	3.9	100	10/8
177	4500	118.4	3008	3.9	100	6/4
196	5000	128.3	3258	3.9	100	6/4
CMP40/45/50s						
Triple Stage						
145	3700	81.5	2071	52.4	1330	10/8
157	4000	85.5	2171	56.3	1430	10/8
169	4300	89.4	2271	60.2	1530	6/4
• 177	4500	92.0	2338	63.0	1600	6/4
189	4800	96.0	2438	66.9	1700	6/4
196	5000	98.6	2505	69.3	1760	6/4
216	5500	108.2	2748	79.1	2010	6/4
236	6000	114.8	2915	85.6	2175	3/1.5
256	6500	121.3	3082	92.1	2340	3/1.5
275	7000	127.9	3248	98.8	2510	3/1.5
CMP40/45/50s						
Hi-Lo						
106	2700	83.0	2108	60.2	1530	10/8
118	3000	88.9	2258	63.0	1600	10/8
• 130	3300	94.8	2408	69.3	1760	10/8

• Indicates preferred common specification.

¹ For overall height raised with load backrest, add 48 in. (1220 mm) to maximum fork height.

² Standard tilt shown. Contact a Clark representative for information on optional tilt.

³ Freelif dimensions shown are without load backrest.

⁴ For overall height lowered with dual drive, deduct 1.1" (28 mm).

Other uprights available, contact a Clark representative.

Grade Clearance

Model	A%	B%
CMP 40	80	38
CMP 45	67	38
CMP 50S	63	38

Available Equipment

- Double auxiliary valve
- Hose adaptations
- Sideshifter
- Hydraulic control options
- Combination stop/tail/backup lights
- Rear work light
- Turn signal lights
- Strobe light
- Backup alarm
- Mirrors
- Convenience console
- Suspension seat, vinyl and cloth
- Operator cab with heater
- Air Conditioning - Diesel
- Seat actuated engine shutdown
- Air cleaner safety element
- Travel speed limit - LPG
- Horizontal exhaust with diesel engine
- Various tire/wheel options

North America CMHC
Worldwide Headquarters
 700 Enterprise Drive
 Lexington, KY 40510
866-252-5275
www.clarkmhc.com

CMP 40/45/50S Specification Sheet
 59-894-0420 Printed in USA CClrev.0305

your authorized CLARK dealer is: